



Mec 103

Specially designed to light up benches and workplaces.

The Mec 103 is a product purposely designed to light up benches and workplaces. The arm can be locked manually using mechanical clutches to ensure product stability despite the strong vibrations it undergoes in work environments.

The reflector consists of two

elements – a glass fibre filled ABS cap and a turned sheet metal reflector with reinforced edge. The product is ideal on parallel lathes, presses, column drills, milling cutters, sharpeners, transfer machines and also on industrial sewing machines and assembly benches.

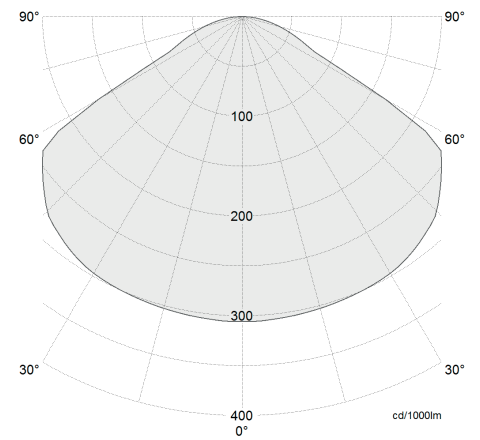
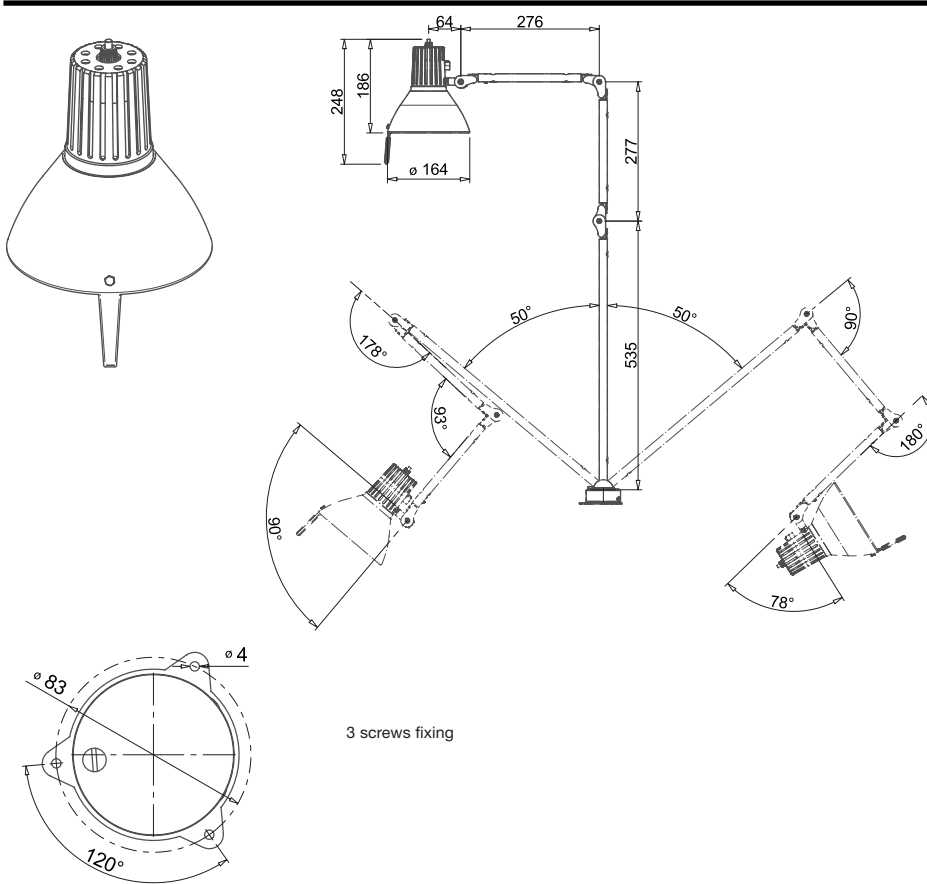



Mec 103

Available with LED and incandescent bulbs, this product is suitable for work environments subject to strong vibrations or where the product has to maintain a fixed position. For more comfortable movement, the reflector is fitted with a handle.

Code	MEC103
Power	60 W
Supply	220-240 V
ES	E27
Reflector's diameter	160 mm
Structure	1012 mm with 4 joints
IP protection	IP20
IK protection	IK04
Class	I
Cable	H03 VVF 3X0.75 170 cm with 2P + T 10 A plug
Fixing	3 screws



ACCESSORIES



AS2

S11*

GP

* the accessory requires the adapter AS2

ORDER CODE

Hammered Black

MEC103NM