

AUGMENTED REALITY



compatible with iOS devices

Designed for applications requiring the presence of a small light source. MC1 is an excellent companion for column drills, operating machines, sewing machines, and to illuminate paintings and works of art.

MC1



Power	25 W	25 W
Supply	24 V	24 V
ES	E14	E14
Reflector size	30 mm	30 mm
Structure	100mm arm with 1 Joint	100mm arm with 1 Joint
IP Protection	IP20	IP20
Class	III	III
Cabling	Sez 2 x 0,75 mm; 100 cm of cable with no plug (24v)	Sez 2 x 0,75 mm; 100 cm of cable with no plug (24v)
Fixing	Fork	Magnet
Colour	Black	Black
Code	MC1	MCICAL

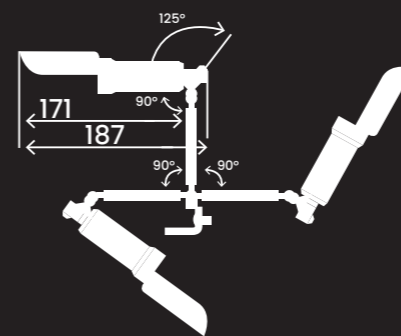

CODE

MC1 With fork

MCICAL With magnet

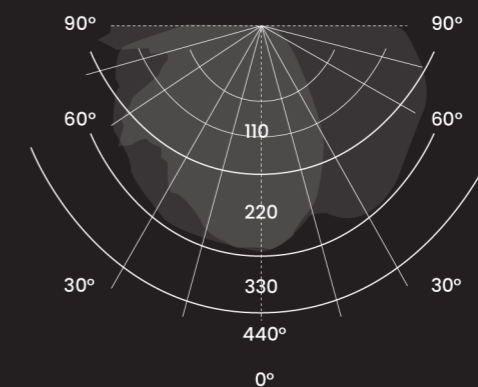
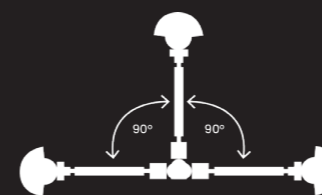

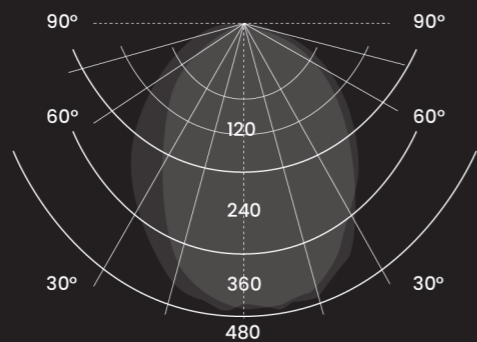

AUGMENTED REALITY



compatible with iOS devices



The product is designed to provide light at 5.000 K and is therefore well suited for use in the goldsmithery field. Thanks to the large rectangular reflector, 160-LED can illuminate extensive working areas. The pantograph arm allows easy movement.

160-LED

ACCESSORIES



S11



S12



S15

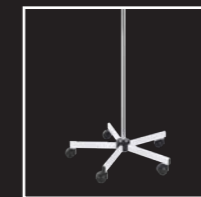

RL

Power	13.7 W
Supply	110-240 V
Illuminance at 50 cm	1.800 lux
Colour Temperature	4.000 K
Light Intensity Adjustment (Dimmer)	5% - 100%
Reflector's size	495 x 95 mm
Diameter of the light field	800 x 650 mm
Product's life	50.000 hours
Structure	Pantograph
IP Protection	IP20
IK Protection	IK05
Cabling	Plug-top transformer with AWG 2X21; plug type C (European - 2 pins) - upon request type G (British - 3 pins)
Class	III
Fixing systems	S11, S12, S15, RL
Colours	Hammered Grey, Hammered White
Code	160-LED-GM, 160-LED-BM

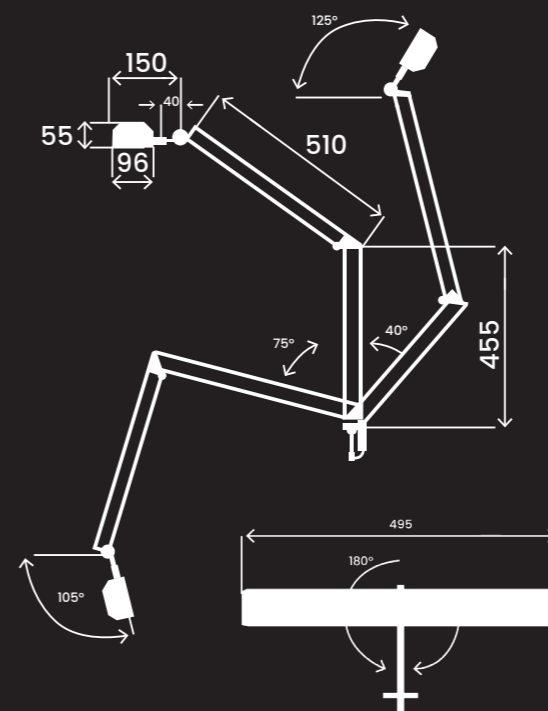

CODE

- GM** 160-LED-GM Hammered Grey
- BM** 160-LED-BM Hammered White

